

PRESCONTROL PRO

PASSIVE INFRARED (PIR) MOTION SENSOR



TECHNICAL PARAMETERS

Power supply:	230V/50Hz
Rated power:	2000 W Max light bulb ~ (resistive load)
Detection range:	360°
Movement range:	max. 9 metres
Presence detection range:	max. 3 metres
Delay time:	from (10 ± 5) seconds to (40 ± 5) minutes adjustable
LUX	daylight or night light adjustable
illumination level:	night light adjustable
Protection class:	II
Working temperature:	25°C (clean environment)
Application:	Indoor only

PRODUCT CHARACTERISTICS

The PIR motion sensor is a precise device that switches on one luminaire or a group of luminaires based on motion detection or presence detection by sensing temperature change. Depending on the type of room, it allows for significant energy savings at a low cost of installation.

APPLICATION

Offices, toilets, service points, booths, checkout counters. All locations where detection and automatic activation of devices based on slight movements is needed, e.g. hand or head movements in a sitting or standing position. Prescontrol Pro sensor switches on or off a luminaire or a group of luminaires and other devices (e.g. ventilation, air-conditioning). The sensor can be connected directly or via a contactor or relay. The sensor can also be used as a precise motion sensor mounted outside the luminaire.

PRESCONTROL PRO

PASSIVE INFRARED (PIR) MOTION SENSOR

PRINCIPLE OF OPERATION

The basis for the operation of the passive infrared motion sensor are small temperature changes in the detection fields. The extremely sensitive pyroelectric detector (infrared detector) reacts to the infrared waves emitted by people, even when the person in a sitting position makes a slight movement of his head or hand, e.g. during office work or in the toilet, and this way activates the luminaire.

OPERATING RANGE

The sensor works within the radius of 360 degrees. The best results are obtained when mounting the device at a height of 2.5 to 3.5 m. The range of motion detection – e.g. of people moving or walking through – is 9 m. The range of "presence detection" – e.g. detection of small hand or head movements – is 3 m.

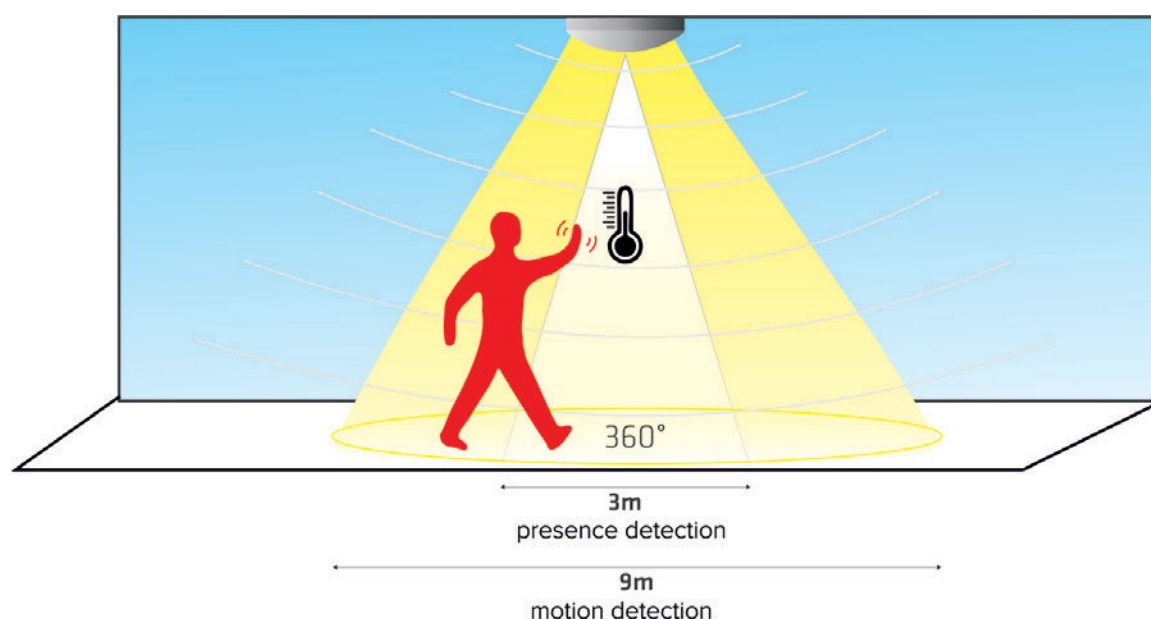

FUNCTIONALITY

The sensor's operating mode can be easily adjusted to individual requirements. The sensor allows to adjust illuminance (day-night identification), length of working time (switch off delay) and effective range of operation (distance from the sensor and detection area).

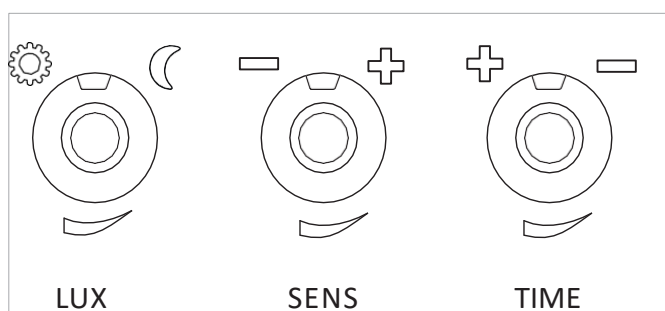

PRECONTROL PRO

PASSIVE INFRARED (PIR) MOTION SENSOR

TECHNICAL DRAWINGS

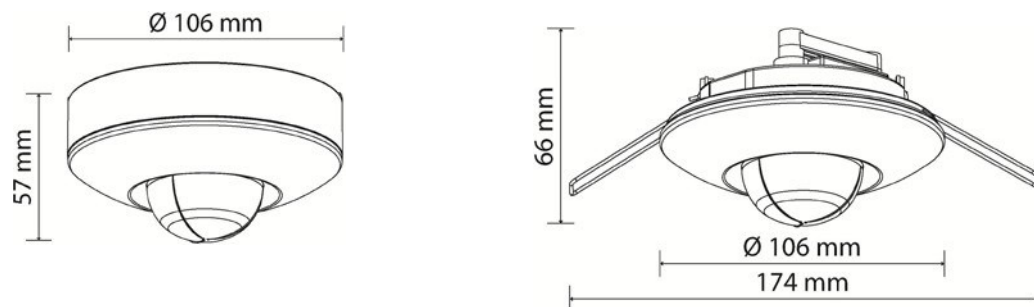

MOUNTING METHOD



surface mounted



flush mounted

TECHNICAL DETAILS



Surface mounting



Flush mounting

INDEX TABLE

	Name	Remarks
W01162	PRECONTROL PRO PIR sensor	Universal ordering index – both surface and flush mounting – see the instruction.

PRECONTROL PRO

EASY STANDARD-BASED CONTROL – LOCATION LIST WITH RECOMMENDED CONTROL OPTIONS

REQUIREMENTS FOR THE LIGHTING OF INDOOR WORKPLACES ACCORDING TO PN-EN 12464-1:2011 STANDARD

OFFICES

Ref. no.	Type of area. Application or activity	Specific requirements
5.26.5	Conference and meeting rooms	Lighting control recommended

PUBLIC GATHERING PLACES – RESTAURANTS AND HOTELS

Ref. no.	Type of area. Application or activity	Specific requirements
5.29.6	Conference rooms	Lighting control recommended

EDUCATIONAL ROOMS – EDUCATIONAL BUILDINGS

Ref. no.	Type of area. Application or activity	Specific requirements
5.36.1	Classrooms, self-study rooms	Lighting control recommended
5.36.2	Classrooms for evening classes and adult education	Lighting control recommended
5.36.4	Auditorium, lecture halls	Lighting control recommended in order to accommodate different power requirements (A/V).

HEALTH CARE ROOMS – TREATMENT ROOMS (GENERAL)

Ref. no.	Type of area. Application or activity	Specific requirements
5.45.1	Dialyses	Lighting control recommended
5.45.2	Dermatology	Lighting control recommended

PRESCONTROL PRO

PASSIVE INFRARED (PIR) MOTION SENSOR

SENSOR USER AND INSTALLATION MANUAL

- 1** We are glad you have bought the PIR sensor. The sensor is intended for indoor use only. Please read the manual before installation and keep it for future reference. **IMPORTANT:** Never modify the device, parts cannot be replaced. Not suitable for use with dimmers. Install in accordance with the IEC installation regulations.

THE SENSOR SHOULD BE INSTALLED BY A QUALIFIED ELECTRICIAN.

2 PRESENCE

The PIR sensor has a motion detection range with a radius of 3 metres. The sensor will detect slight movement (head movements, slow walking, etc.) within this range to turn on or maintain the lighting. If you want to achieve the best results, we suggest you take into account the following information:

1. The range of presence detection is 3 metres.
2. We suggest setting the delay time to more than 10 minutes.
3. The PIR sensor must operate at a temperature of about 25°C or lower and in a clean environment (normal temperature)

3 SENSOR LOCATION

When selecting the place of installation, consider the following:

1. The sensor operates with optimum performance at a mounting height of 2.5 to 3.5 m (see Fig. 1)
2. Avoid installation near heat sources such as radiators, air vents, air conditioners that can be a source of signals received by the sensor.
3. Avoid installation in bright lighting conditions, the PIR sensor does not work when the lux control level is set (Position).
4. Avoid installation near sources of strong electromagnetic interference, e.g. near an electric motor or fluorescent lamp power supply.
5. Cable entry holes (min. 4.0 x 5.0 mm), can be opened if necessary.

4 SENSOR INSTALLATION

Before starting any electrical work, make sure that the power is turned off by turning off and removing the appropriate fuse. (See Fig. 2A and Fig. 2B)

A. Ceiling installation (Fig. 2A)

1. Remove the front cover and disassemble the main unit by prying it out with a screwdriver in the places marked with an arrow
2. Unscrew the cable holder, remove the junction box with the terminal block
3. Use the bottom cover to mark the location of the screw holes on the installation surface. Drill through the wall to a depth of about 35 mm, install wall plugs, carefully screw the mounting box with screws.
Be careful to avoid drilling or screwing into hidden electrical wiring.
4. Connect the power cables to the terminal block
5. Install the junction box with the terminal block, install the cable holder.
6. Align and attach the main unit to the bottom cover, and then attach the front cover.

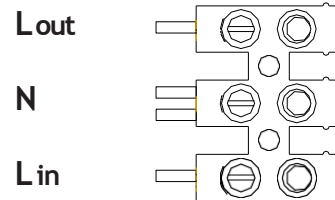
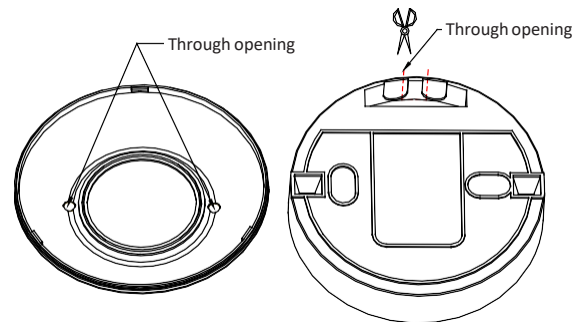
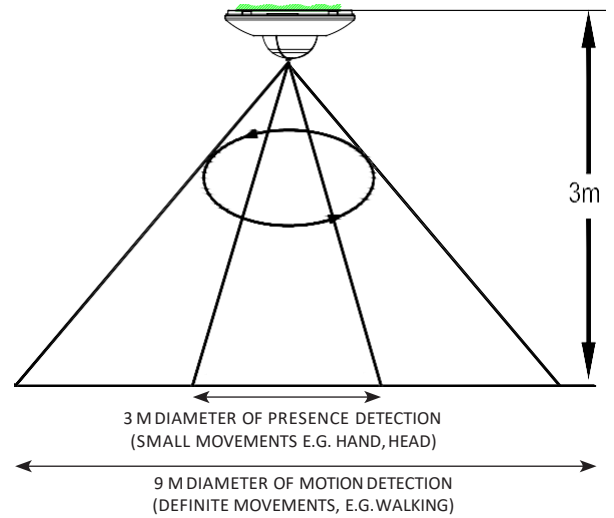

PRESCONTROL PRO

PASSIVE INFRARED (PIR) MOTION SENSOR

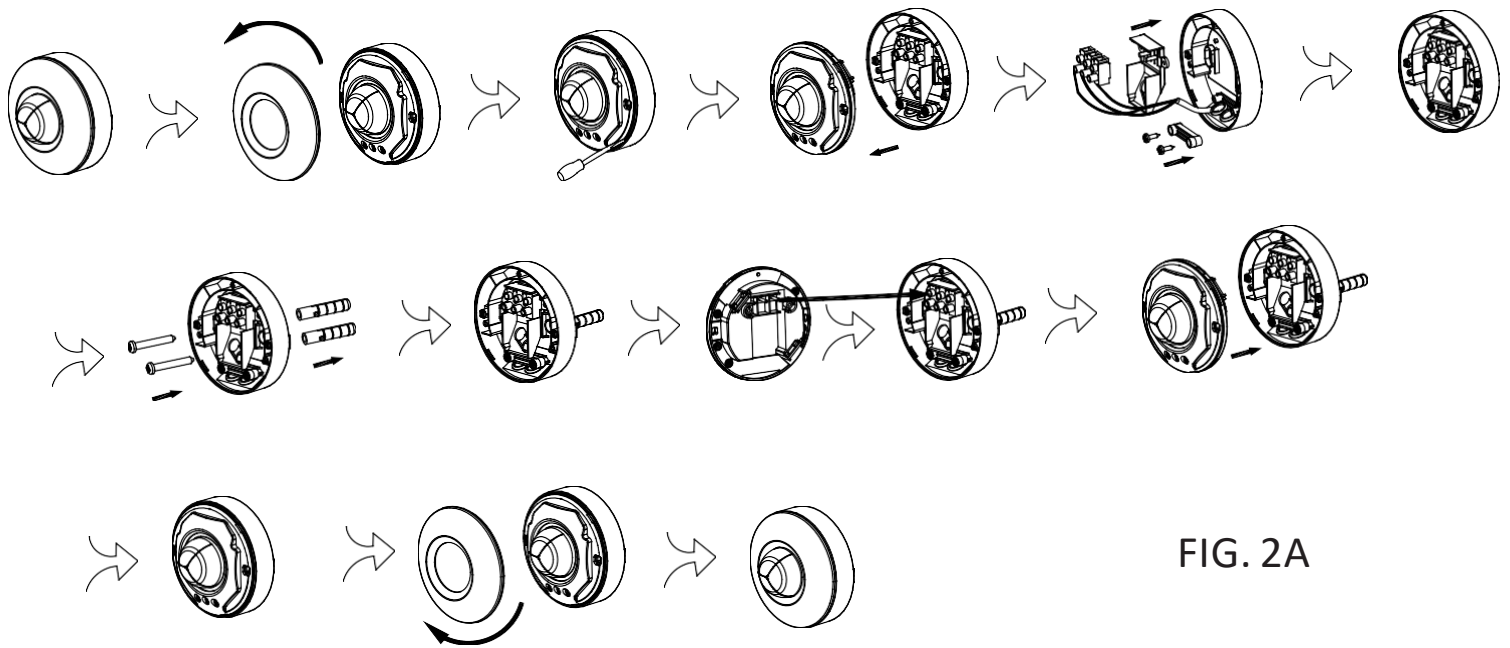

FIG. 2A

B. Recessed mounting (Fig. 2b)

1. Open the spring to position Fig. 2B
2. Press the spring into the groove and then close the spring
3. Unscrew the cable holder, remove the junction box with the terminal block.
4. Connect the power cables to the terminal block
5. Install the junction box with the terminal block, install the cable holder.
6. Drill a hole with a diameter of 80 mm in the ceiling
7. Install the main unit in the hole in the ceiling using springs. After completing the installation, you can set the PIR sensor working status

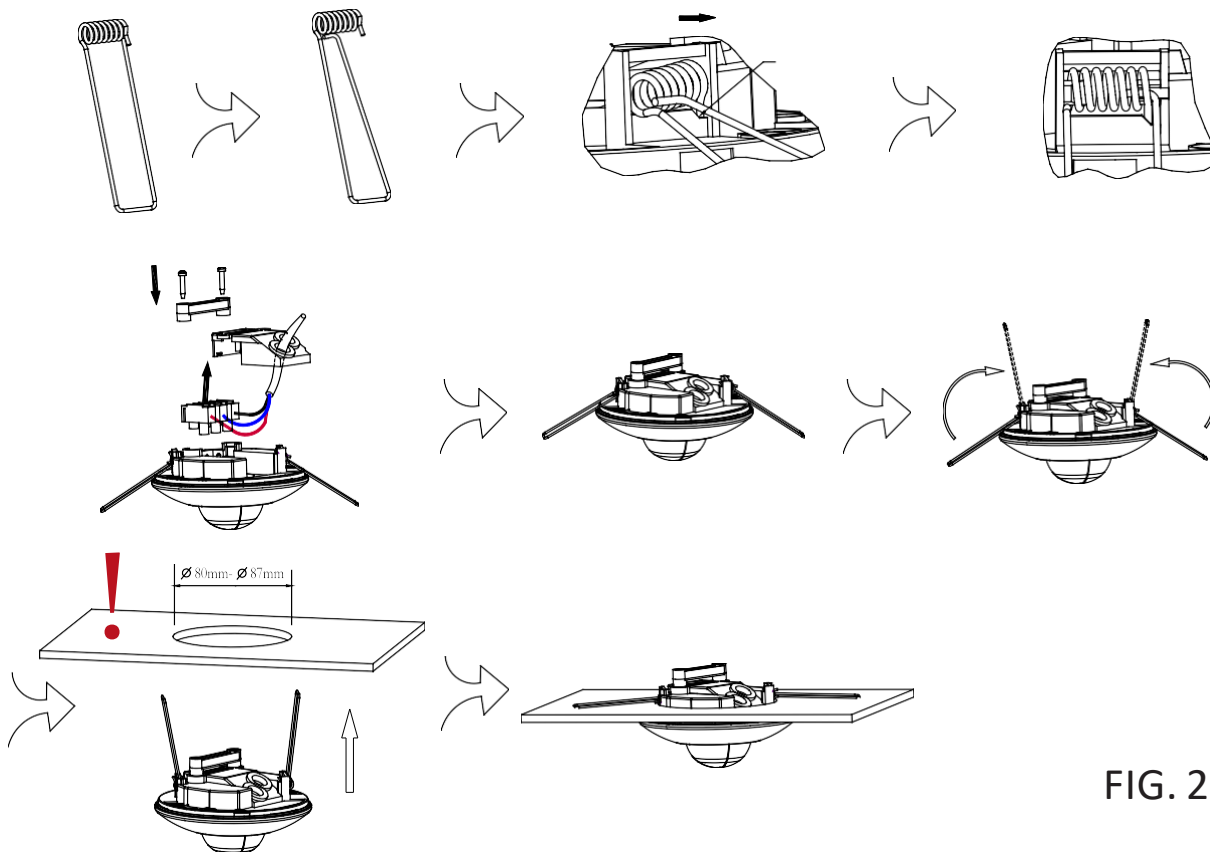

FIG. 2B

PRESCONTROL PRO

PASSIVE INFRARED (PIR) MOTION SENSOR

5 LUX BRIGHTNESS LEVEL ADJUSTMENT

The LUX control is a built-in sensor (photocell) that detects light and darkness.

(☀ position – means that the light will be switched on during the day and at night.

(☾ position – means that the light will be switched on only at night.

You can set the device to work at the desired level of light intensity by adjusting the LUX knob

TIME delay adjustment:

Duration means the time the lighting is switched on once activated by the PIR sensor. Duration can be adjusted from (10 ± 5) seconds to (40 ± 5) minutes. Turning the TIME knob from (+) to (-) decreases the delay time.

Note: When the light is switched on by the PIR sensor, any subsequent motion/presence detection will reset the counting of the delay time.

SENS – sensitivity adjustment:

Sensitivity is the maximum distance at which the PIR sensor can be activated by body movement. Turning the SENS knob from (+) to (-) will decrease the sensitivity.

6 PARAMETER ADJUSTMENT

1. Set the LUX knob to the (☀) light position, turn on the power and wait half a minute until the control circuit stabilizes. At this stage, make sure the TIME knob is set to the minimum delay time (-) position. The lighting will turn on and will stay on for about 30 seconds (within 60 seconds.)

2. Position the sensor in the desired detection area

3. Use another person to move along the centre of the detection area until the lighting is on.

4. Set the delay time to the required level.

To set the level of light intensity at which the sensor will automatically turn on the lighting at night, turn the LUX knob from daylight to night. If you need to switch on the lighting in advance, e.g. at dusk, wait for the desired brightness level, then slowly turn the LUX knob from night to daylight while someone is passing through the centre of the detection area. When the light is on, release the LUX knob. You may need to make further adjustments to achieve the desired brightness level setting.

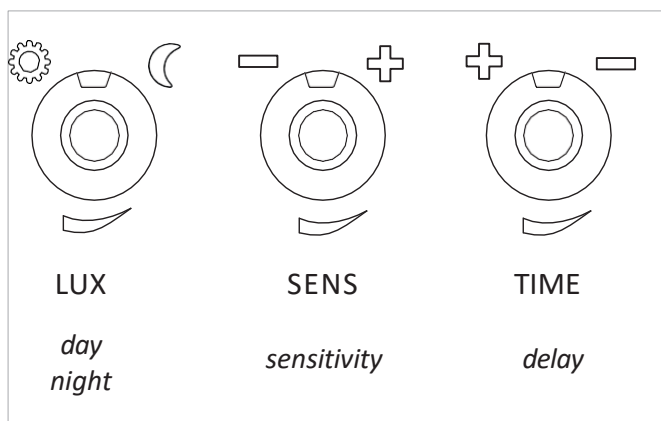

The manufacturer reserves the right to make constructional changes in the course of product improvement or upgrade the presented product. The product specification sheet is not a commercial offer.

Sheet update date: 09/10/2024